

## BF Mod-Plus Marathon™ - Adhesive Applicator

The BF MOD-PLUS MARATHON™ adhesive applicator is an air-operated, single or multi-orifice hot melt adhesive applicator assembly with an integrated filter cartridge which prevents particulate matter from obstructing flow through the nozzle orifice. The Marathon's™ screw-on nozzle seat allows for fast and easy nozzle change, and the optional stroke adjustment allows for fine-tuning of optimum adhesive cut-off at the nozzle tip.

### BF Mod-Plus Marathon™ Applicator:

- Standard air open/air close module provides positive shut-off and on-cycle
- Platinum sensor provides better temperature control over nickel sensors
- Compatible with most competitive configurations
- Water resistant optional
- Built-in, heated filter has the largest surface area on the market, resulting in longer filter life and less nozzle clogging

### Reliability

Air open/air close standard gives clean, sharp cut-off every time.

### Performance

Built-in, heated filter better maintains a clean nozzle orifice.

### Simplicity

Easy-to-remove module body saves time during module changes.

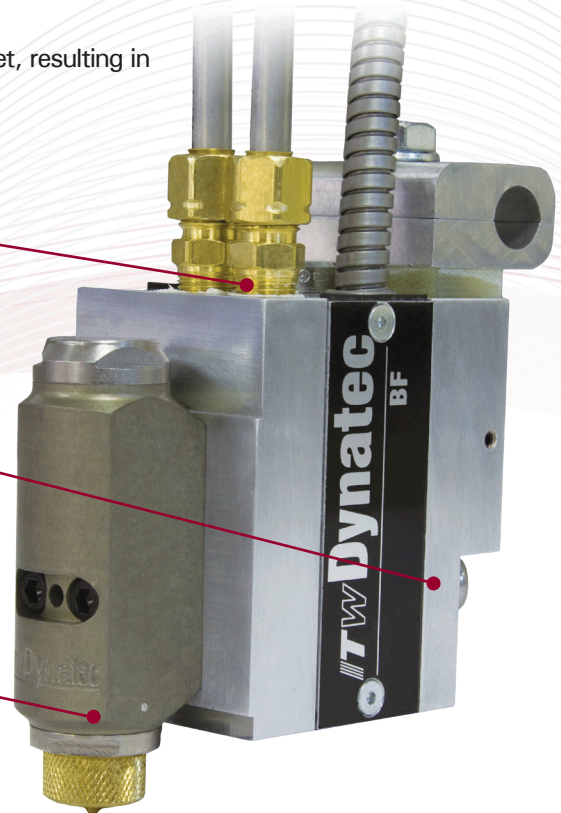

ITW Dynatec - BF Mod-Plus Marathon™ Applicator

## The Dynatec Difference...

### Air open/air close standard

Over time, adhesive applicator modules that use an air open/spring close system can lose spring tension, resulting in stringing and poor cut-offs. The BF Mod-Plus Marathon™ applicator module is designed to operate as an air open/air close system that does not rely on a spring to close the orifice during operation. The result is both cleaner cut-off and better

operation over a longer operating lifespan. While this feature may be optional on competitive modules, only ITW Dynatec offers this feature standard on the BF Mod-Plus Marathon™ adhesive applicator.

# BF Mod-Plus Marathon™ - Adhesive Applicator

System	BF Mod-Plus Marathon™
Operating Temperature Range	38°C to 218°C (100°F to 425°F)
Minimum Operating Pneumatic Pressure	5 bar (74 psi)
Maximum Operating Pneumatic Pressure	9.7 bar (140 psi)
Minimum Adhesive Pressure	41 bar (600 psi)
Maximum Adhesive Pressure	68 bar (1,000 psi)
Minimum Adhesive Viscosity	None
Maximum Adhesive Viscosity	20,000 cps
Maximum On/Off Cycle Speed	5,000 cycles/minute (400 series MAC® valve)

\* Specifications are based on 1,000 cps adhesive

Dimensions	BF Mod-Plus Marathon™
Height (H)	96.1 mm (3.78 in)
Depth (D)	81.0 mm (3.19 in)
Width (W)	44 mm (1.73 in)

## More Filter - Less Clogging

- Over 6 times the surface area of competitive standard filters.
- Longer filter life and less nozzle clogging over competitive standard filters.
- Built-in filter is heated for better adhesive temperature control.
- Built-in filter purge valve for easy back flushing further increases filter life and reduces nozzle clogging issues.

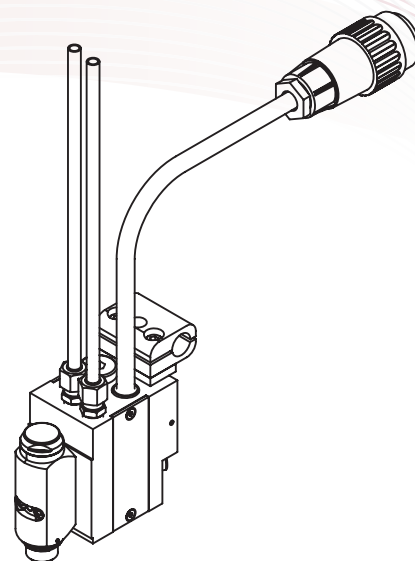
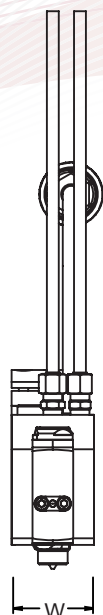
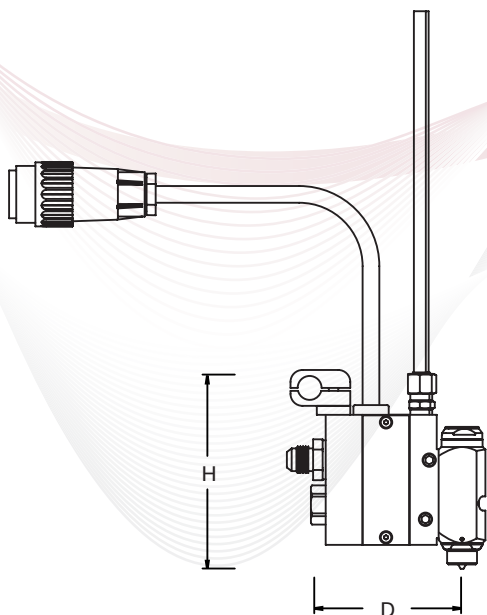

**ITW Dynatec**

**ASIA**  
ITW Dynatec Hong Kong  
Unit A-B, 11/FI., Leahander  
Centre 28  
Wang Wo Tsai Street  
Tsuen Wan NT Hong Kong

**AMERICAS**  
ITW Dynatec  
31 Volunteer Drive  
Hendersonville, TN 37075  
Telephone 615-824-3634  
+1.800.860.6150  
Fax +1.615.264.5248  
dynatec@itwdynatec.com

**JAPAN**  
ITW Dynatec K.K.  
Tsukimura Building 5th Floor  
26-11, Nishikamata 7-chome  
Ota-ku, Tokyo 144-0051, Japan  
Telephone +81.3.5703.5501  
Fax +81.3.5703.5505  
info@itwdynatec.co.jp

**EUROPE, AFRICA and MIDDLE EAST**  
ITW Dynatec GmbH  
Industriestrasse 28  
D-40822 Mettmann, Germany  
Telephone +49.210.4915.0  
Fax +49.210.491.5111  
e.mail@itwdynatec.de

© 4/2009 ITW Dynatec  
ITW Dynatec reserves the right to discontinue or change specifications, designs, materials and equipment without notice or obligation.

Visit us at [www.itwdynatec.com](http://www.itwdynatec.com)